

EDC-OPS-2/24V

Home | Security | Housings | for Dome Cameras

EDC-OPS-2/24V

Pendant Mount Outdoor Dome Housing with Sunshield,

Tinted Bubble 6.5", 24VAC

Art-Nr. 74136



Main Features

Outdoor housing for Fastrax I - III dome cameras

Tinted bubble 6.5" (165mm)

Prepared for wall and ceiling mounting

Sunshield, heater and blower kit included

Supply voltage: 24VAC/50-60Hz

Protection rating: IP66

Option: Wall and ceiling mount brackets, power box

Option: Connection cable #74143 & #74144

Specifications

Camera fixing	dome
Weight	3,6kg
Bubble	165mm (6.5"), tinted acrylic plastic
Supply voltage	24VAC, 50/60Hz
Heater	yes
Power consumption	approx. 75watts for heater, blower and incl. dome camera
Power consumption (heater)	approx. 50W
Temperature range (operation)	-45°C ~+50°C
Protection rating	IP66
Connection	1 1/2"PT thread
Load capacity	approx. 2kg
Mounting	wall or ceiling pendant mount
Vandalism resistant	no
Housing	outdoor
Housing material	aluminium

EDC-OPS-2/24V

(Continuation Specifications)

Sunshield	yes
Colour (housing)	Pantone Cool Gray 1C
Colour (bubble)	tinted

Optional accessories

70449	NE-128	Voltage supply unit 230V/24VAC-5A, IP66
74127	EDC-WMB1	Wall Mount for EDC(H) Dome Cameras with Mounting Kit
74140	EDC-RTB2	Pole & Roof Mount Bracket for Fastrax 2 outdoor Housings & EDCH
74128	EDC-CMT1	Ceiling Mount Tube with Flange Plate for EDC(H) Dome Cameras with Mounting Kit
74125	EDC-AKS1	Power&Connection Box with Mounting Bracket for In/Outdoor, 230V-24VAC/3.0A
74163	EDC-AKS2	Power&Connection Box with Connection Cable 3.5m, In/Outdoor, 230V-24VAC/3.0A
74143	EDC-OPX/IPX-CC1	Connection cable for EDC-xxx-2 Fastrax III, Standard Domes in In/Outdoor Housing
74090	EDC-PRMB	Parapet and Roof Mount Bracket for Fastrax Housings 1-2(w./o. Dome Housing)

EDC-OPS-2/24V

Home | Security | Housings | for Dome Cameras

Technical drawing

Deckenmontage (inkl. Deckenmontagerohr EDC-CMT1, #74128) /
Ceiling mount (incl. ceiling mount tube with flange plate EDC-CMT1, #74128)

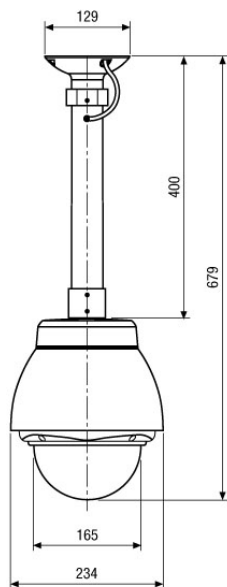

Wandmontage (inkl. Wandmontagearm EDC-WMB1, #74127) /
Wall mount (incl. wall mount bracket EDC-WMB1, #74127)

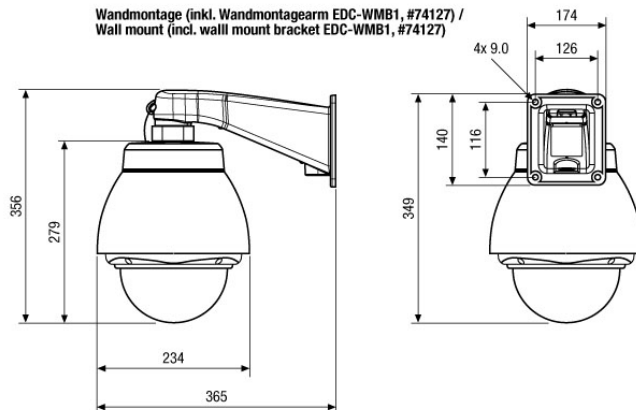

Wandmontage (inkl. Anschlussbox mit Netzgerät und Montagearm EDC-AKS-1, #74125) /
Wall mount (incl. power & connection box with mounting bracket EDC-AKS-1, #74125)

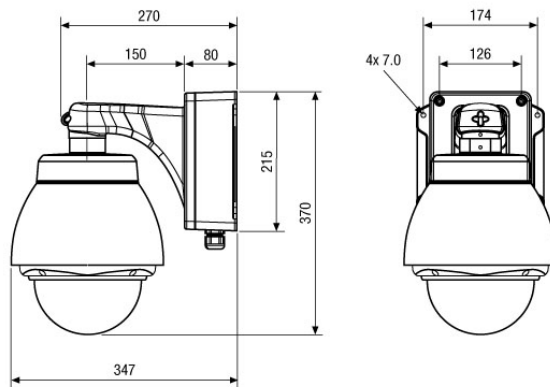

Der Wandmontagearm, die Deckenhalterung und die Anschlussbox mit Netzgerät sind im Lieferumfang des Domegehäuses nicht enthalten.
Wall bracket, ceiling tube and power & connection box are not included with the dome camera housing.

Maße / Dimensions: mm

SLD Security & Communications
The Old Forge, Ockham Lane, Ockham, Surrey GU236PH England
Phone +44.1483225633 · Fax +44.1483225634
sales@sld.co.uk · www.sld.co.uk

