

EDMC/CWB-1

Home | Security | Dome Cameras | Accessories

EDMC/CWB-1

Wall or Pendant Mount Kit f. Dome Camera Series EDMC,

NTD, NLD, NXD & VKCD-1375

Art-Nr. 74155



Specifications

Colour	Pantone Cool Gray 1C
Weight	1.2kg
Load capacity	5.0kg
Cable connection	We recommend a multicore cable with approx. 10mm diam., for example the eneo MCAB-1, edp no. 87404
Connection	1"PT thread
Protection rating	IP65 (in conjunction with the cable #87404 only)
Housing	Aluminium, Pipes: Steel

Optional accessories

74055	EDC-PM7	Pole Mount Adapter for EDC-IPx1/OPx1 Housings and Wall Bracket EDC/WMB1
87404	MCAB-1	Camera/PT Head Connecting Cable, for Video, Power, RS-Control, Network, 1m
74054	EDC-CMA2	Corner Mount Adapter for EDC-IPx1/OPx1 Housings and Wall Bracket EDC/WMB1
74107	EDMC-RTB	Roof Mount Bracket for Minitrax Camera Series, Outdoor Installation

EDMC/CWB-1

Home | Security | Dome Cameras | Accessories

Technical drawing

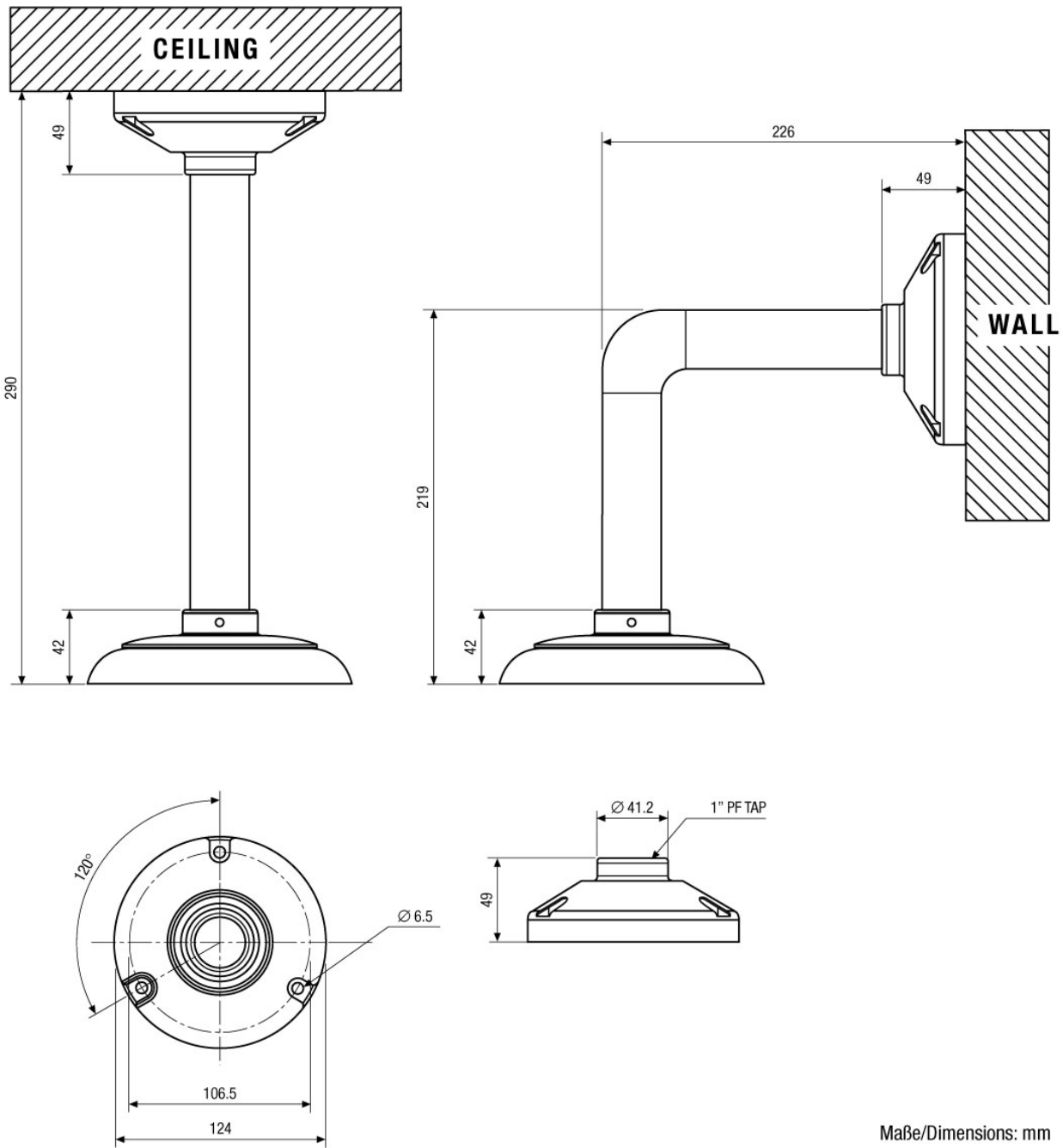

SLD Security & Communications
The Old Forge, Ockham Lane, Ockham, Surrey GU236PH England
Phone +44.1483225633 · Fax +44.1483225634
sales@sld.co.uk · www.sld.co.uk

