

VKC-1367IR-1850

Home | Security | Cameras | Plug & Play

VKC-1367IR-1850
1/3" Camera, Day&Night, F1.5/18-50mm, 540TVL,
IR Illumination, 12VDC/24VAC

Art-Nr. 96094



Main Features

Weatherproof camera with swivel head bracket
1/3" day/night CCD camera with varifocal lens
Sensitivity of 0.16Lux at F1.2
Removable IR Cut Filter
Sensitivity enhancement: 6x/8x (DSS function)
Automatic frame integration rate control

Optimized noise reduction function (DSP S/W)
IR illumination by 15 integrated 850nm LEDs
80m night observation distance (20° LED's)
Dynamic (light) intensity control (DIC)
IR corrected lens with no-focus-shift
Hidden cable routing / Protection rating: IP67

Specifications

Series	eneo W3 Plug & Play
System	day&night
Video standard	CCIR/PAL
Sensor size	1/3"
Imager	CCD, Sony Super HAD II Interline Transfer
Active picture elements	440,000 (H) 752 x (V) 582 pixels
Synchronization	internal
Signal-to-noise ratio	50dB (AGC OFF)
Horizontal resolution	540 TVL
Sensitivity (at 50% video signal)	0,16 Lux, (colour), 0.1Lux (B&W) at F1.2 (measured)
Automatic electronic shutter (ESC)	1/50 ~ 1/100,000sec.
Low speed shutter	yes, 6x/8x, slectable
Automatic gain control (AGC)	28dB max.

VKC-1367IR-1850

(Continuation Specifications)

Digital Noise Reduction (DNR)	no
White balance	2000 ~8000K, automatic tracking
Backlight compensation	BLC, center weighted (ON/OFF switchable)
Wide Dynamic Range (WDR)	no
Aperture Correction (APC)	horizontal and vertical
IR cut filter	switchable
Internal adjustments	4 Dip switches: ELC/ALC (Shutter/Auto-Iris), Day/Night On/Off. Potentiometer: Level for DC controlled iris.
Video outputs	composite (CVBS)
Lens type	varifocal
Lens	F1.5 ~F360/18 ~50mm with galvanometer-driven iris
Focal length	18 mm - 50 mm
PTZ support	no
Digital zoom	no
Horizontal angle of view	14,6° - 5,6°
Iris control	DC
MOD (Minimum object distance)	1,0 m
Filter screw size	not available
Illumination	infrared, 15x LED's 850nm at 20° illumination angle. Due to an integrated light sensor the LED illumination will be switched ON/OFF, depending on environmental illumination conditions.
Illumination range	approx. 80m (at a good light reflexion and 40% Videosignal)
Activity detection	no
Serial interfaces	no
Cable connection	Wiring for video and voltage supply made, accessible from outside (1.5m long, Video: BNC jack 12/24V input: 2-pin screw terminal)
Kind of mounting	Integrated wall mount with ball joint
Mounting	wall mount
Temperature range (operation)	-30°C ~+50°C
Housing material	aluminium
Housing	outdoor
Integrated wall mount	yes
Hidden cable management	yes
Window screen	Acrylic glass (clear)
Sunshield	no
Window heater	no
Clear Shield	no
Colour (housing)	Pantone 7541
Vandalism resistant	no
Protection rating	IP67

VKC-1367IR-1850

(Continuation Specifications)

Alarm inputs	-
Alarm outputs	-
Supply voltage	12VDC, 24VAC, (10.5 ~30VDC, 12 ~29VAC)
Power consumption	5W
Dimensions (HxWxD)	see drawing
Weight	690g
Parts supplied	Camera, Manual, "Easy installation" adapter cable, Heat shrink tube
Certificates	CE

Optional accessories

77773	VT-PS12DCDT1	PSU 12VDC/1.0A, Regulated, Desktop Version, 1.8m Cables each w. open ends
70495	VT-PS12DC-7	Plugable PSU w. Cont. & UK Mains plug-in 100-240VAC/12VDC-1.25A, Regulated
73179	PM-42	Pole Mount Adapter, for Housing Series Candid, W3 Plug&Play
88148	W3 INST-KIT1	Installation Kit for W3 Housings with Hidden Junction Boxes

VKC-1367IR-1850

Home | Security | Cameras | Plug & Play

Technical drawing

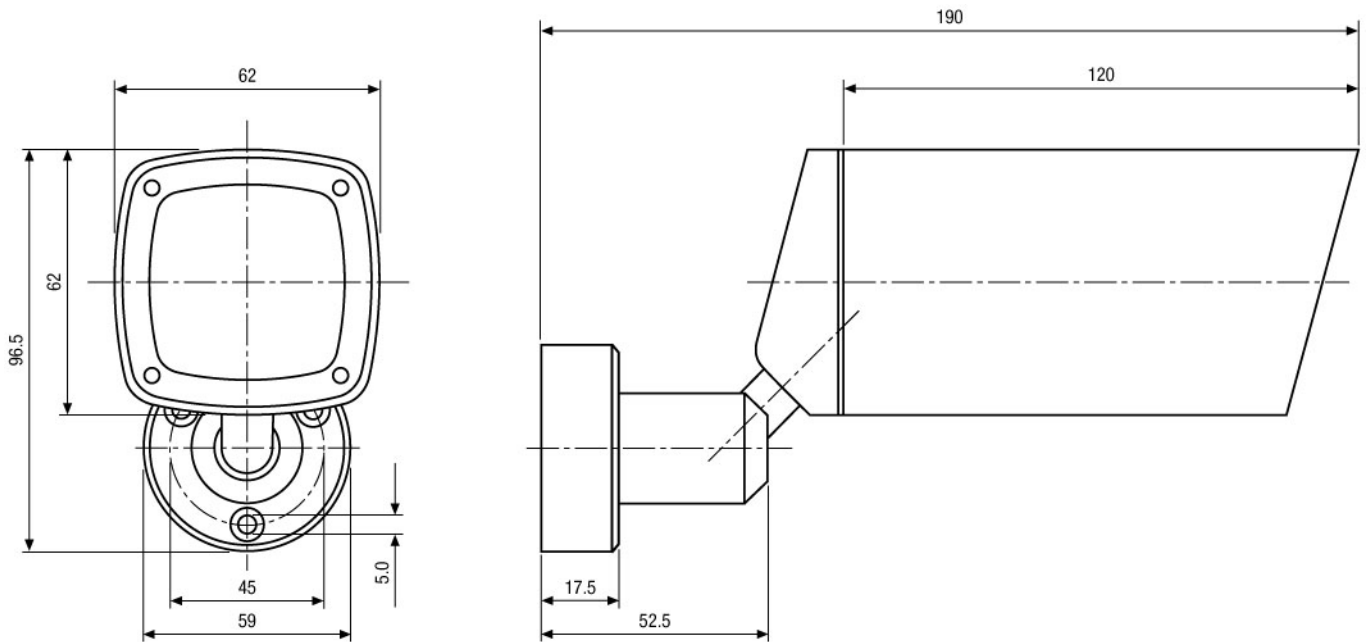

Maße/Dimensions: mm

SLD Security & Communications
The Old Forge, Ockham Lane, Ockham, Surrey GU236PH England
Phone +44.1483225633 · Fax +44.1483225634
sales@sld.co.uk · www.sld.co.uk

