

VKCD-1334SM/210

Home | Security | Dome Cameras | Fixed

VKCD-1334SM/210
1/3" Dome, Fixed, Day&Night, 2,8-10,5mm, 600TVL,

12VDC

Art-Nr. 92576



Main Features

1/3" Sony Super HAD II CCD	Selectable digital noise reduction (SDNR)
Sensitivity of 0.15Lux at F1.2 (colour)	Privacy masking/Mirror function/Motion detection
On-screen display (OSD)	Integrated varifocal lens: F1.2/2.8-10.5mm
Removable IR cut filter (IRCF)	Manual 3-axis camera gimbal
Selectable backlight compensation (SBLC)	Supply voltage: 12VDC
High speed shutter control (MES/ESC)	For wall and ceiling surface mounting

Specifications

System	day&night
Sensor size	1/3"
Imager	CCD
Horizontal resolution	600 TVL
Sensitivity (at 50% video signal)	0,15 Lux
Sensitivity (at 50% video signal)	(colour), 0.06Lux (B&W) at F1.2 (measured)
Low speed shutter	no
Digital Noise Reduction (DNR)	yes
Backlight compensation	BLC
Wide Dynamic Range (WDR)	no
IR cut filter	switchable
Activity detection	yes
Digital zoom	no

VKCD-1334SM/210

(Continuation Specifications)

Lens type	varifocal
Focal length	2,8 mm - 10,5 mm
Horizontal angle of view	81,2° - 25,8°
MOD (Minimum object distance)	0,1 m
Video outputs	composite (CVBS)
Alarm inputs	-
Alarm outputs	-
PTZ support	no
Illumination	no
Serial interfaces	no
Housing material	plastic
Colour (bubble)	clear
Colour (housing)	Pantone Warm Gray 1C
Mounting	ceiling mount, wall mount
Supply voltage	12VDC
Power consumption	2.0W max.
Temperature range (operation)	-10°C ~+50°C
Protection rating	n/a
Vandalism resistant	no
Weight	400g
Certificates	CE
Iris control	DC
Heater	no
Housing	indoor

Optional accessories

70535	VT-PS12DC-8	Plug-in Power Supply Unit 100-240VAC 12VDC (1.0Amp), Regulated, with DC Plug
70495	VT-PS12DC-7	Plugable PSU w. Cont. & UK Mains plug-in 100-240VAC/12VDC-1.25A, Regulated
77773	VT-PS12DCDT1	PSU 12VDC/1.0A, Regulated, Desktop Version, 1.8m Cables each w. open ends

VKCD-1334SM/210

Home | Security | Dome Cameras | Fixed

Technical drawing

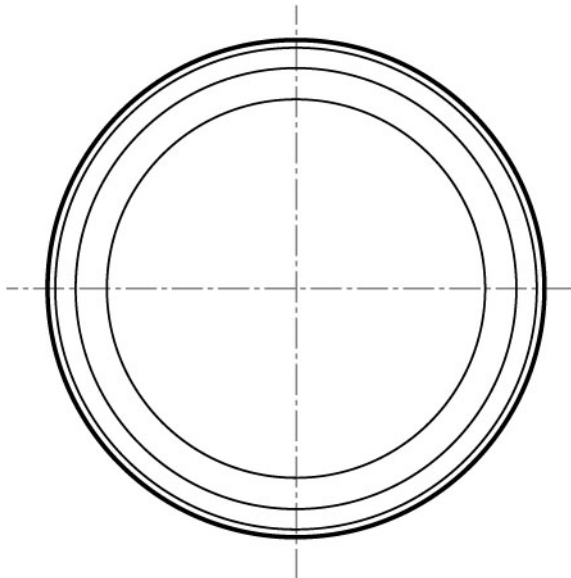
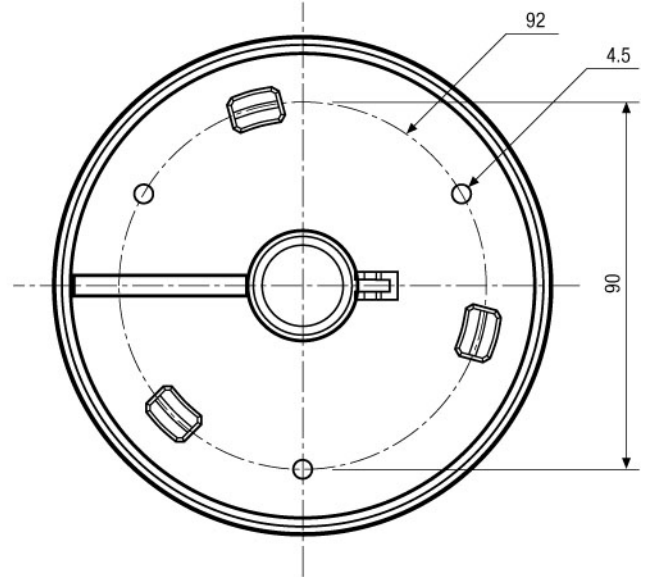
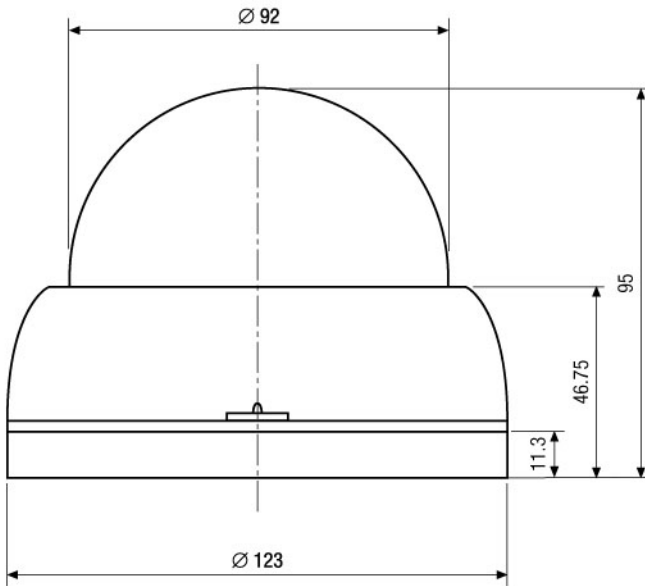

Maße/Dimensions: mm

SLD Security & Communications
The Old Forge, Ockham Lane, Ockham, Surrey GU236PH England
Phone +44.1483225633 · Fax +44.1483225634
sales@sld.co.uk · www.sld.co.uk

